



SHORT-THROW PROJECTOR WALL MOUNT PROJ-WM

For Mitsubishi Projector models XD500U-ST and WD500U-ST



Features:

- Quick and Simple Installation Process
- Ideal for Interactive and Non-Interactive White Boards
- Adjustable Length Arm to accommodate diagonal image size of: 40"-100" (XD500U-ST; XGA) or 50"-120" (WD500U-ST; WXGA)
- Cable Routing Inside the Arm for Neat Appearance
- High Quality, Rugged Construction and Modern Design

Includes PROJ-UCM-PRO2 Universal Projector Mount:

- For projectors 10 lbs. or less
- Includes (4) universal mounting legs w/ built-in leveling adjustments
- Super fast, one-person projector installation
- MagnaGuide™ Technology — powerful magnets "draw" the projector into place for perfect projector alignment every time
- Tilt and Roll: +/-6°; 360° Mount Rotation
- Radial Glide Technology™ lets you lock all axis of tilt, roll, yaw with a single screw
- Equipped with Lock-It™ security hardware
- Mount mates with industry standard 1.5" threaded pipe
- Limited Lifetime Warranty

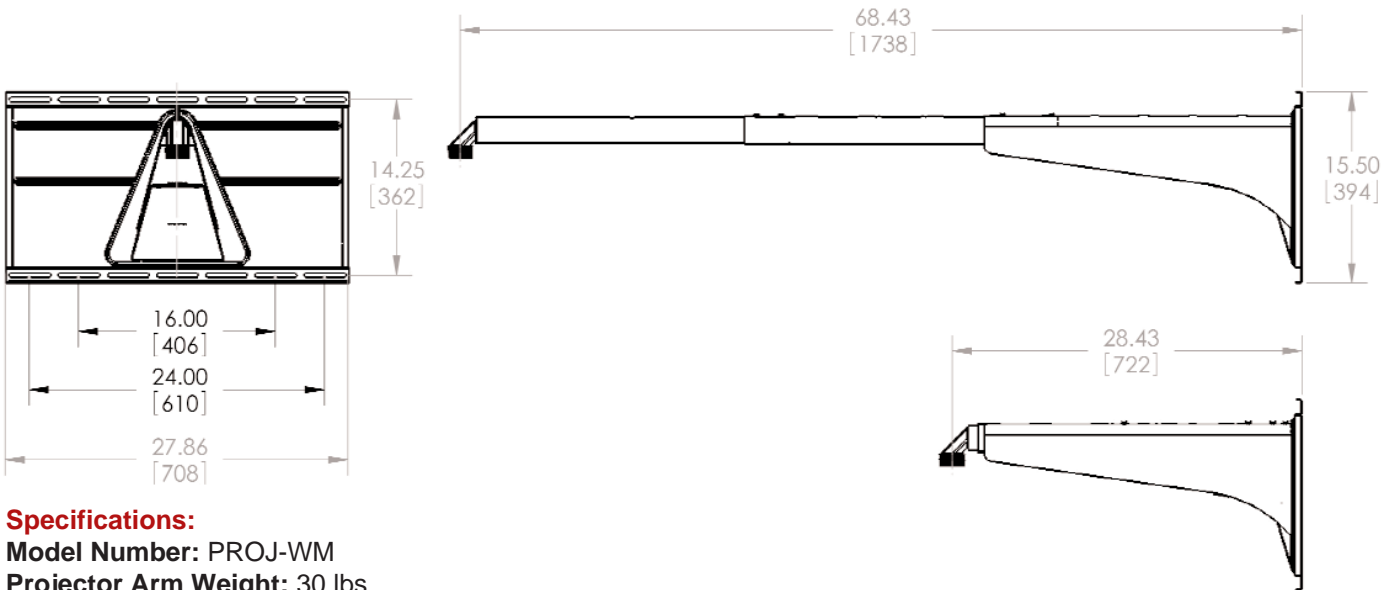

Specifications:

Model Number: PROJ-WM

Projector Arm Weight: 30 lbs.

Projector Mount Weight Rating: Up to 10 lbs.

Carton Dimensions: 15 x 18.5 x 30"

Ship Weight: 39 lbs.

Color: White