



MITSUBISHI ELECTRIC

MULTIMEDIA DATA/VIDEO PROJECTORS

Specifications			
Model	WL6700U	XL6600U	XL6500U
Display technology	1.2" TFT Poly silicon x 3	1.3" TFT Poly silicon x 3	
Resolution	1366 x 800 dots	1024 x 768 dots	
Brightness	5000lm	6000lm	5000lm
Contrast	1000 : 1		
Zoom / focus	Power (zoom ratio : 1.3 : 1)		
Picture size	60" ~ 250"	60" ~ 300"	
Source lamp	220W (Shut off Time 4000Hrs) with Low Mode, 275W (Shut off Time 2000Hrs) with Standard Mode		
Computer compatibility	640 x 400 ~ 1600 x 1200, True : 1366 x 800, Sync on green available	640 x 400 ~ 1600 x 1200, True : 1024 x 768, Sync on green available	
Video compatibility	NTSC / NTSC 4.43 / PAL (including PAL-M, N) / SECAM / PAL-60 Component Video : 480i/p (525i/p), 576i/p (625i/p), 720p (750p 50/60Hz), 1080i (1125i 50/60Hz), 1080p (1125p 50/60Hz), SCART (RGB + 1V sync, only Mini D-SUB 15pin)		
Input terminals	PC : 5BNC x 1, Mini D-SUB 15pin x 1, DVI-D (with HDCP) x 1, PC Audio : Stereo mini jack (ø3.5mm) x 2, Video (1) : RCA x 1 or BNC x 1, Video (2) : S-VIDEO (4pin) x 1 or S-VIDEO Y/C (BNC), Video Audio : RCA (L/R) x 2		
Output terminals	RGB : mini D-SUB 15pin x 1, Audio : Stereo mini jack (ø3.5mm) x 1		
Communication terminals	LAN (RJ-45) x 1 (Projector control), RS-232C (D-SUB 9pin) x 1, USB x 1 (Mouse control), Wired remote (IN) : Stereo mini jack (ø3.5mm) x 1, Wired remote (OUT) : Stereo mini jack (ø3.5mm) x 1		
Audio speaker	10W mono		
Dimensions (W x H x D)	443 x 207 x 434mm / 17.4 x 8.1 x 17.1 inch (including terminal cover)		
Weight	9.8kg / 21.6lbs (excluding terminal cover)		
Power supply	AC100 ~ 240V, 50 / 60Hz		

* Windows is a registered trademark of Microsoft Corporation.
 * Macintosh is a registered trademark of Apple Computer Inc.
 * SXGA, XGA, SVGA, WXGA are registered trademarks of IBM Corporation.
 * All brand names and product names are trademarks, registered trademarks or trade names of their respective holders.

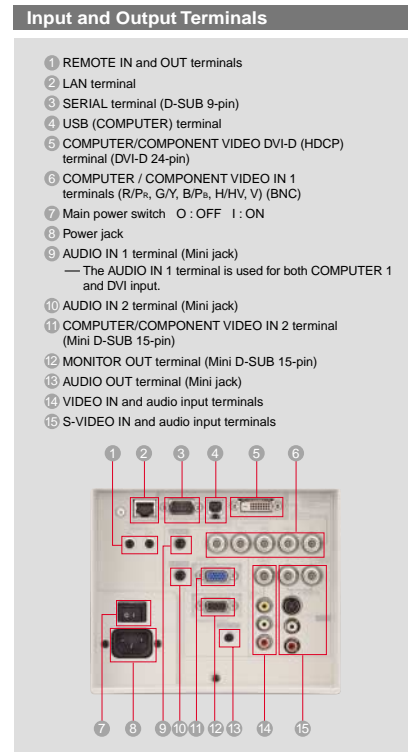
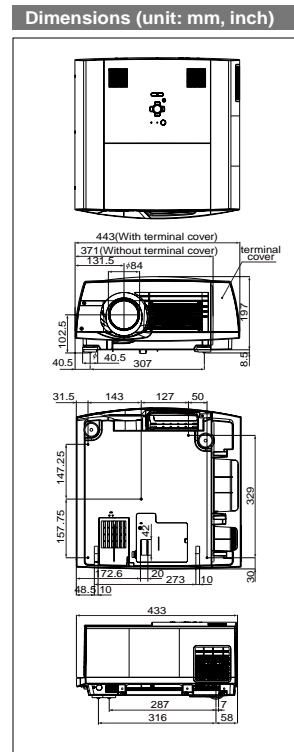

Screen size and projection distance

Refer to the following table to determine the screen size and projection distance.

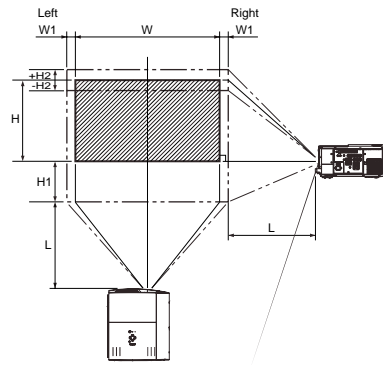

■ XL6600U / XL6600LU / XL6500U / XL6500LU																		
		Screen				Distance from Screen (L)				Movable V Position from Default Position				Movable H Position from Default Position				
Diagonal size		Width		Height		Max. Zoom		Min. Zoom		Down(H1)		Up(H2)		Left(W1)		Right(W1)		
inch	cm	inch	cm	inch	cm	inch	m	inch	m	inch	cm	inch	cm	inch	cm	inch	cm	
60	152	48	122	36	91	89	2.3	114	2.9	18	~	-2	46	~	-5	3	~	7
80	203	64	163	48	122	120	3.0	153	3.9	24	~	-2	61	~	-6	3	~	8
100	254	80	203	60	152	150	3.8	191	4.9	30	~	-3	76	~	-8	4	~	9
120	305	96	244	72	183	181	4.6	230	5.8	36	~	-4	91	~	-9	4	~	10
150	381	120	305	90	229	227	5.8	289	7.3	45	~	-5	114	~	-11	5	~	12
200	508	160	406	120	305	304	7.7	386	9.8	60	~	-6	152	~	-15	5	~	14
250	635	200	508	150	381	381	9.7	483	12.3	75	~	-8	191	~	-19	7	~	17
300	762	240	610	180	457	458	11.6	-	-	90	~	-9	229	~	-23	8	~	20

■ WL6700U / WL6700LU																		
		Screen				Distance from Screen (L)				Movable V Position from Default Position				Movable H Position from Default Position				
Diagonal size		Width		Height		Max. Zoom		Min. Zoom		Down(H1)		Up(H2)		Left(W1)		Right(W1)		
inch	cm	inch	cm	inch	cm	inch	m	inch	m	inch	cm	inch	cm	inch	cm	inch	cm	
60	152	52	132	30	77	96	2.4	122	3.1	15	~	2	39	~	5	3	~	7
80	203	69	175	40	103	129	3.3	164	4.2	21	~	3	52	~	7	4	~	9
100	254	86	219	51	128	162	4.1	206	5.2	26	~	4	65	~	9	4	~	11
120	305	104	263	61	154	195	5.0	248	6.3	31	~	4	78	~	11	5	~	13
150	381	129	329	76	193	245	6.2	311	7.9	38	~	5	97	~	14	7	~	17
200	508	173	438	101	257	328	8.3	416	10.6	51	~	7	129	~	18	9	~	22
250	635	216	548	126	321	411	10.4	-	-	63	~	9	161	~	23	11	~	28

Optional Lenses

■ WL6700U / WL6700LU				
Model	OL-X500SZ	OL-X500LZ	OL-X500TZ	OL-X500FR(F)
Type	Short Throw Zoom Lens	Long Throw Zoom Lens	Tele Throw Zoom Lens	Rease Projection Short Throw Fix Lens (on axis)
F NO.	F2.0 - 2.3	F2.5 - 3.2	F2.5 - 3.4	F2.5
f	37 - 44mm	64 - 90mm	93 - 140mm	22mm
Throw ratio	1.3 - 1.6	2.4 - 3.3	3.4 - 5.2	0.8
Off-set axis	15 (up) : -1 (down)*	15 (up) : -1 (down)*	15 (up) : -1 (down)*	1 : 1 (on axis)*
Zoom / Focus	Motorized (1.2 : 1)	Manual (1.4 : 1)	Manual (1.5 : 1)	Manual
Weight	1.4kg / 3.1lbs	1.7kg / 3.8lbs	1.7kg / 3.8lbs	1.7kg / 3.8lbs
Length	177mm (max)	204mm (max)	205mm (max)	174mm (max)
Lens diameter	84mm	84mm	84mm	123.6mm

* The lens shift function allows the picture off-set to be adjusted between 15 : -1 (off axis) and 1 : 1 (on axis).
 Lens shift cannot be used with OL-X500FR(F).

■ XL6600U / XL6600LU / XL6500U / XL6500LU				
Model	OL-X500SZ	OL-X500LZ	OL-X500TZ	OL-X500FR(F)
Type	Short Throw Zoom Lens	Long Throw Zoom Lens	Tele Throw Zoom Lens	Rease Projection Short Throw Fix Lens (on axis)
F NO.	F2.0 - 2.3	F2.5 - 3.2	F2.5 - 3.4	F2.5
f	37 - 44mm	64 - 90mm	93 - 140mm	22mm
Throw ratio	1.3 - 1.6	2.4 - 3.3	3.4 - 5.2	0.8
Off-set axis	19 (up) : 1 (down)*	19 (up) : 1 (down)*	19 (up) : 1 (down)*	1 : 1 (on axis)*
Zoom / Focus	Motorized (1.2 : 1)	Manual (1.4 : 1)	Manual (1.5 : 1)	Manual
Weight	1.4kg / 3.1lbs	1.7kg / 3.8lbs	1.7kg / 3.8lbs	1.7kg / 3.8lbs
Length	177mm (max)	204mm (max)	205mm (max)	174mm (max)
Lens diameter	84mm	84mm	84mm	123.6mm

* The lens shift function allows the picture off-set to be adjusted between 19 : 1 (off axis) and 1 : 1 (on axis).
 Lens shift cannot be used with OL-X500FR(F).



MITSUBISHI ELECTRIC CORPORATION
 HEAD OFFICE : TOKYO BLDG., 2-7-3, MARUNOUCHI, CHIYODA-KU, TOKYO 100-8310, JAPAN
Global.MitsubishiElectric.com/projectors/

MITSUBISHI DIGITAL ELECTRONICS OF AMERICA, INC.
 Presentation Products Division
www.mitsubishi-presentations.com

MITSUBISHI ELECTRIC SALES CANADA, INC.
 Display Imaging Solutions Division
www.MitsubishiElectric.ca

Ultra-Bright Images, High-Performance Projection



New

WL6700U/LU
 XL6600U/LU
 XL6500U/LU

Impress your Audience with the High Performance Mitsubishi Installation Projectors series

The Mitsubishi WL6700U/LU, XL6600U/LU and XL6500U/LU installation projectors will capture the attention of your audience by delivering sharp, bright images with vibrant colors and exception details.

Ultra-Brightness

Super bright 6000lm*

The XL6600U/LU delivers super bright 6000 lumen* images. A high brightness level for presenting in large meeting rooms and conference halls.

*WL6700U/LU, XL6500U/LU are 5000 lumens.

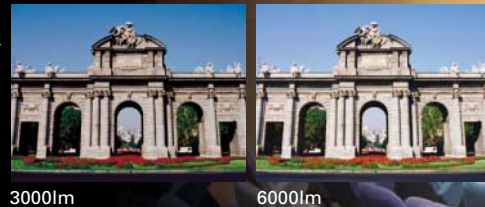

Designed for Flexible Installations

2-way Mechanical Lens Shift (Vertical & Horizontal)

Lens shift allows images to be shifted both horizontally and vertically, letting you position the projector conveniently anywhere in the room. Additionally, Digital Keystone Correction reduces line distortion by allowing for vertical correction to create a more natural-looking picture even when it is difficult to set up the unit perfectly perpendicular with the screen.



Optional Lenses

A wide variety of optional lenses is available to suit any operating or user requirement.

Optional Lenses Line-up



*The CA-XL6600 (FR) Front Cabinet (sold separately) is required when using the OL-X500FR Rear Projection Short Throw Fix Lens.

Impressive Picture Quality

Color Enhancer

Optimum source reproduction is achieved with six different viewing modes: Auto, Presentation, Standard, Theater, sRGB, and User. Depending on the input signal, you can adjust the best color setting on your own.

3D Y/C digital comb filter and 3D noise reduction

The luminance and chrominance (Y/C) signals of images are separated with 3D processing for enhanced brightness. Cross-colorization (rainbow-like noise patterns) and dotcrawl (checkerboard-like noise patterns) are reduced, producing a clear and distinct image.

Developed to ensure standard, uniform color reproduction regardless of the type of display used, sRGB color profile technology uses independent color coordinates common to all display technologies. As a result, it helps to eliminate hue variations that occur between different display systems and more accurately matches the way colors look.

To find out the details of sRGB, visit us at : <http://global.mitsubishielectric.com/bu/projectors/technology/>



Versatile Input Terminals

Equipped with a RJ45 network terminal, administrators can remotely manage their projectors from a web browser via the Local Area Network (LAN). Administrators can check projector status such as lamp usage, change input selections, remotely power on or off, as well as receive email alerts if an error occurs. In addition, these projectors support RS232C standards as well as BNC connectivity for long cable setups with PC or video inputs.

Terminal Cover

Includes a terminal cover to cover up any visible connectivity cables.



Wider Screen Range (WL6700U/LU only)

Whatever the screen you use is, WL6700U/LU can automatically detect the input signal, and display an optimum screen size to either Auto (16:10), Auto (16:9), or Auto (4:3). Users will no longer need to worry about selecting the optional screen size since the projector can automatically detect the signal and select the optimal mode. Also since the WL6700U/LU incorporate a 1366 x 800 WXGA panel, they will support multiple WXGA images - 1280 x 768, 1280 x 800, 1360 x 768, 1366 x 768 at its native resolution without compression.

Long 4000hrs Lamp Life

Designed with a lamp temperature controlling system, the WL6700U/LU, XL6600U/LU, XL6500U/LU can support a lamp life of up to 4000 hours*1. The long life lamp makes dramatic reductions in overall cost of ownership by decreasing the frequency of lamp replacements.

Lamp Replacement Frequency*2

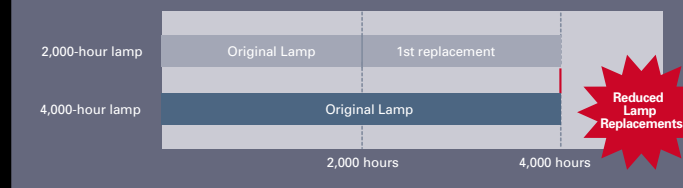

(*1): When used in Lamp Low mode. Maximum lamp life at standard mode use is 2,000 hours. (*2): Lamp life refers to the average time required for brightness to be reduced by half, and not the time specified in the warranty. Use time may vary widely by the environment and conditions, and whether or not cleaning and other maintenance procedures are followed.

PJ Link available (Projector control by network LAN)

To monitor and projectors and facilitate maintenance, PJ Link is a diagnostic system that provides control over key projector functions such as...filter clogging. Being able to remotely manage via a LAN is ideal for administrators to control their projectors from a remote system.

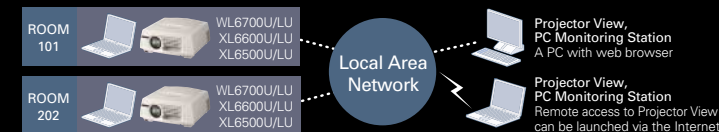

High image quality PinP* (Real Motion)

This innovative technology allows you to show two images (two motion/live images) simultaneously on screen. Images from two different sources (PC and video) can be shown together on the main screen and PIP to double the impact of any presentation. An increase in video processing to 60 frames / sec. provides smoother image transitions and it is also possible to zoom up on the picture.

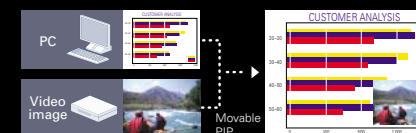

*XL6600U/LU, XL6500U/LU, only. Not compatible with the WL6700U/LU.

Projector Line-up



User-friendly Functions

Ultra Quiet 29dBA Operation

Fan noise emanating from a projector can get annoying during a presentation or videoconference, but now that's a thing of the past. The WL6700U/LU, XL6600U/LU, XL6500U/LU offer a significantly low noise level of only 29dBA (low lamp mode). As a result, your audience can enjoy the presentation or conference without noisy distractions from the projector.

Split (side-by-side) window function* brings expression to the next level

The split-screen function of conventional XGA projectors overlap, with the sub-screen in front of the main screen. Our WXGA panels present perfectly parallel split windows, placing two screens side-by-side. When displays are simultaneous and identical in scale, comparative viewing is clear and effective.

*WL6700U/LU only. Not compatible with the XL6600U/LU, XL6500U/LU.



Anti-Theft Features (password security, motion alarm, screen capture)

Through software, password menus helps lock out access to operation and a customized splash or logo screen can appear when powering on the projector to thwart would-be burglars. From a hardware standpoint, a motion alarm is built into the cable cover; if an outsider attempts to forcibly remove the projector from its mount, a loud alarm will help drive off the potential thief.

■ Motion alarm

Once the motion alarm is set, unauthorized attempts to remove the projector will cause the alarm to sound. Undetectable externally as it is built-in, the alarm is battery powered and features a "safety pin" that prevents accidental activation during projector maintenance.

