

P-SERIES

PRODUCT CATALOGUE

AIR CONDITIONER & HEAT PUMP



 **MITSUBISHI ELECTRIC**
Changes for the Better



Mr. SLIM™



P-SERIES



The Attraction of Being Untraditional

■ Mr. Slim P-Series is the ductless solution for demanding environments that require an efficient and reliable heating or cooling system. P-Series ductless systems are stylish, compact, and more attractive than traditional systems. Advanced technology also means your Mr. Slim ductless system will run more efficiently than a conventional unit, saving you from rising energy costs.



Designed for the Toughest Environment

■ No two buildings are alike. Each design, each floor plan, each room offers its own challenges for something as important as proper air conditioning and circulation.



Mr. Slim systems are designed to adapt to your needs. Reliable, easy to install, and extremely quiet, Mr. Slim systems are powerful enough for the toughest situations, from offices and server rooms to equipment rooms, restaurants and retail locations.

TECHNOLOGY AT WORK

ENERGY EFFICIENCY

Variable Compressor Speed Inverter Technology



At the heart of Mr. Slim P-Series ductless air conditioners and heat pumps lies Variable Compressor Speed Inverter (VCSI) technology. Unlike conventional machines which only cycle between On and Off, VCSI systems detect changes in room temperature and readjust the compressor speed to provide high-speed cooling or heating as needed. This means the space maintains a consistent, accurate temperature for the ultimate in comfort, all while using only the power that's needed. By adjusting the air conditioning capacity to run more efficiently, your energy costs are reduced.

VCSI technology saves energy in two ways:

VCSI system varies the compressor speed to match the additional load with the potential capacity. When the needs of a room expand – more people in a conference room or auditorium, or an increase in equipment in a server room – so do the needs to maintain consistent temperature levels. By allocating

VCSI Systems	Conventional Systems
VCSI compressor speeds up and slows down to maintain the conditioned space temperature.	Conventional compressor turns on and off to maintain the temperature. A compressor draws more amps at start-up than any other time.
Energy consumed by a VCSI compressor is directly related to the required amount of cooling or heating. (Capacity changes as needed.)	Conventional compressor consumes maximum amount of energy to produce maximum amount of cooling or heating at all times. (Capacity does not change.)
VCSI compressor helps system reach its set point quicker by running at a higher RPM for a shorter period of time, then ramps down to maintain temperature.	Conventional compressor runs at same RPM for longer period of time, then switches on and off to maintain temperature.
Indoor temperature swing is minimized with the VCSI system because the indoor coil activates longer. As temperature changes slightly, compressor speed also adjusts slightly to compensate.	Conventional system kicks back on at full speed to compensate for small changes in temperature.

potential capacity to meet the changing demands, VCSI system uses only the energy needed in any given situation.

VCSI system operates efficiently at partial load conditions. Once the desired temperature of the room is reached, the compressor slows down to maintain a constant temperature. By slightly adjusting compressor speed rather than shutting off and on again, energy consumption is kept at a minimum. This is because VCSI system is operating at partial load for maximum efficiency, thus no more excess energy use wasted for running maximum capacity unnecessary on a fixed speed system.



Extra Energy Savings

Compressor speed is precisely controlled to maximize efficiency, changing speeds according to the heating and cooling loads of a room. This lets Mr. Slim systems reach the desired temperature faster while reducing power consumption for extra energy savings.

Optimum Temperature Control

Unlike conventional units which start up and turn off repetitively, the variable compressor detects subtle changes in room temperature and adjusts its speed automatically. This means less temperature fluctuation for a more comfortable environment.

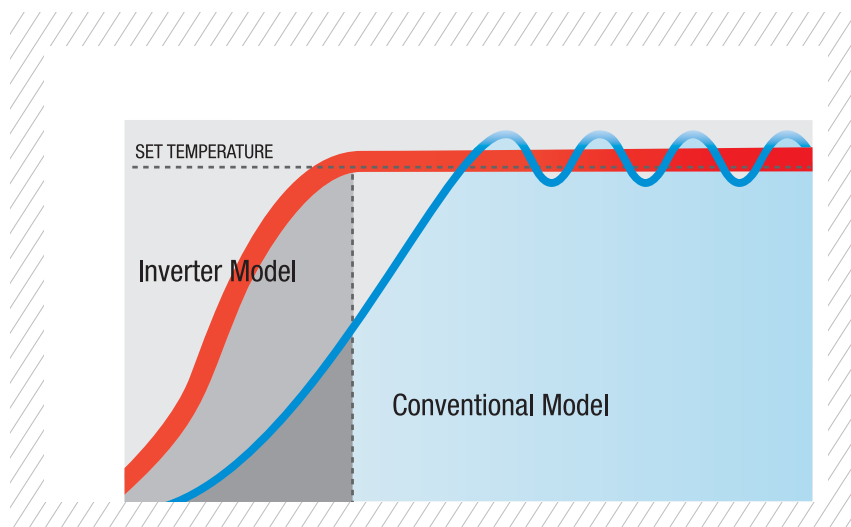

Highly Efficient DC Scroll Compressor

■ The scroll compressor is equipped with a Frame Compliance Mechanism that allows movement in the axial direction of the frame supporting the cradle scroll. This reduces both leaking and friction loss, allowing very high efficiency throughout the speed range.

Reluctance DC Rotor

■ The rotor is equipped with powerful neodymium magnets that use reluctance torque to produce magnetic torque for more efficient operation.

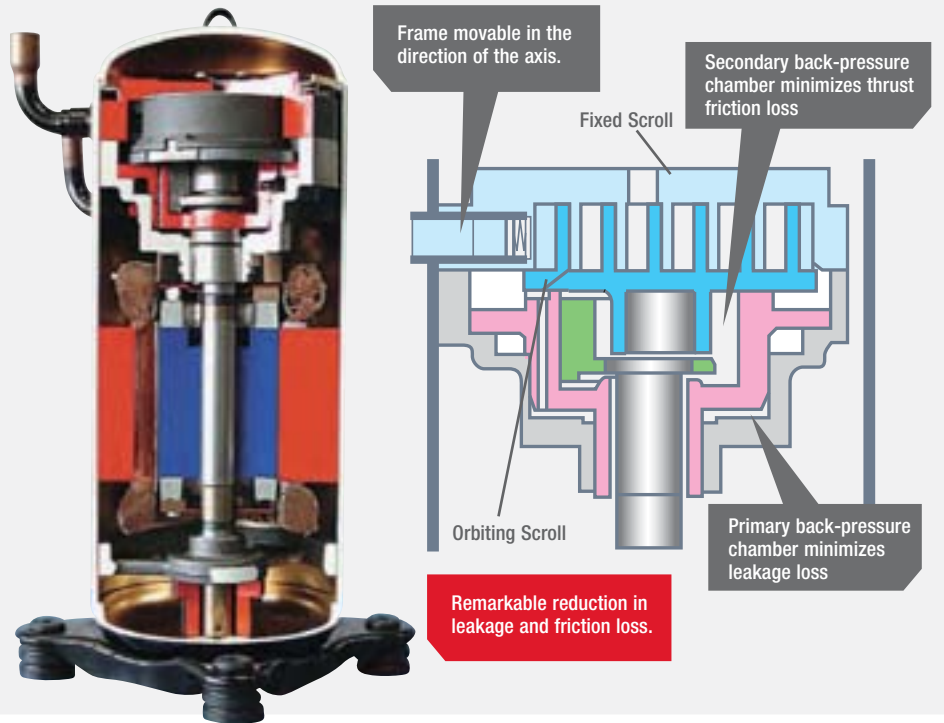

PCA and PLA Fresh Air Intakes

■ Mr. Slim PCA (ceiling suspended) and PLA (ceiling recessed) models allow fresh air in through ducting connected to the indoor units. For advanced control of indoor air quality, interlocked operation featuring Lossnay Energy Recovery Ventilators is also available.

Optional Remote Indoor Temperature Sensor

■ For the utmost in accurate temperature reading. Simply install this optional add-on sensor on a wall, above a window, or wherever else in the room you'd like the Mr. Slim unit to monitor the indoor temperature.



PAM

■ Pulse Amplitude Modulation controls the form of the current wave so that it conforms to the supply voltage wave. With PAM control, up to 98% of the input power supply is effectively used.

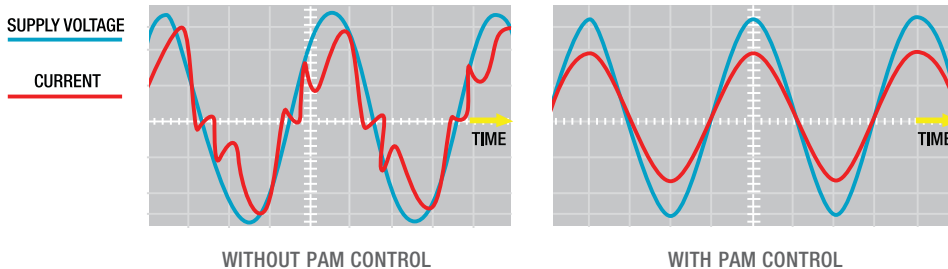

TECHNOLOGY AT WORK

SILENT OPERATION AND ADVANCED CONTROL

Twin Systems for Large Areas

Advantages of Mr. Slim Twin Systems:

- Only one outdoor unit needed, reducing exterior space requirements
- Interior units work together to heat or cool large areas
- Easy installation
- Various indoor combinations available

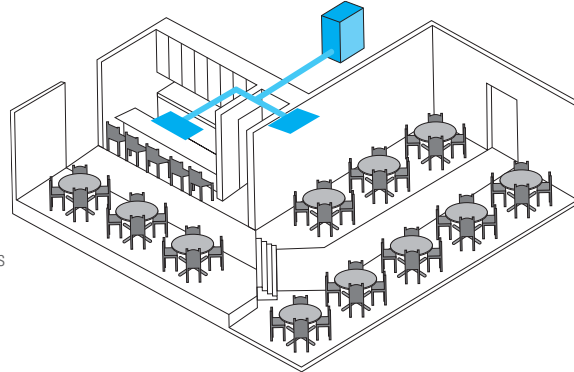

Not all spaces are created equal. Whether it's an L-shaped room or a large conference centre, Mr. Slim P-Series allows two indoor units to operate simultaneously with a single outdoor unit, providing you with all your heating and cooling needs. Temperatures remain consistent throughout the room leaving no corner unreached.

*Available only on PUY-A24/36NHA, PUZ-A24/36NHA and PUZ-HA36NHA

Flat Fin

The highly reliable flat fin is designed to prevent clogging, keeping the unit at maximum efficiency throughout its life span.

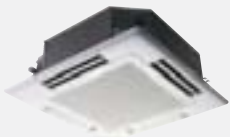
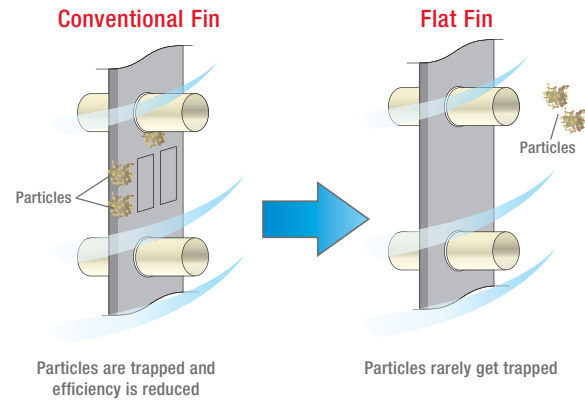
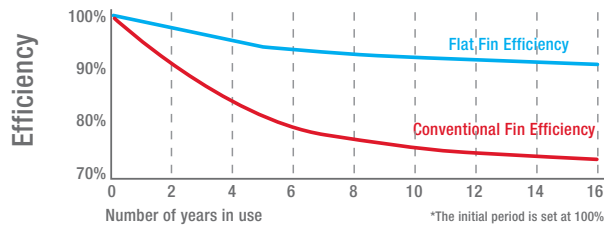

Indoor Unit
ONLY
27dB(A)

Super-Quiet Technology

Inside the unit, the multi-angled heat exchanger has a modified fin shape that reduces air resistance for a smoother, quieter airflow. This lowers noise level to only 27dB(A) during normal operation for the new cassette units, making it one of the quietest indoor units in the industry.

DC Fan Motor

The fan of the outdoor unit is powered by a DC motor, featuring up to 60% greater efficiency than an equivalent AC motor.

Ultra-Silent Outdoor Unit

Aside from the high-efficiency motor, improvements to the fan blade design and the new grille shape make the outdoor unit one of the quietest in the industry. Plus when outside temperatures drop, the external unit reduces operating noise another 3dB(A) by switching to low-noise mode*:

Low-Noise Priority Function

The low-noise priority function is available by connecting a commercially available timer or selector switch.

Outdoor Unit

LOW-NOISE MODE

NIGHT
47dB(A)
(IN COOLING MODE)

DAY
50dB(A)
(IN COOLING MODE)

* At outdoor temperature of 25°C

Slim Smart Remote Control

■ The brains behind Mr. Slim P-Series can be found here in the ultra-thin microprocessor remote control. Not only does it allow you to keep room comfort exactly where you want it, you can also see the status of the entire system with just a glance.

The Slim Smart Remote Control connects indoor and outdoor units to a central location to give you an array of temperature and airflow controls, enhanced service and maintenance functions, management security features and multiple systems control.

Slim Smart Remote Control features include:

Liquid Crystal Display

■ The large-size digital display lets you see the operation and control status with just a glance. Also features menu-driven programming.

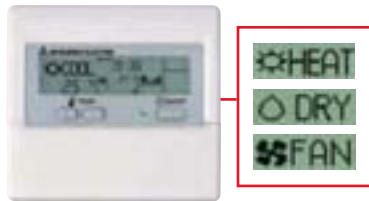

Multi-Language Display

■ Display can be switched to one of 8 different languages.

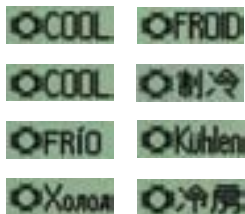

English, French, Italian, Chinese, Spanish, German, Russian, & Japanese

Operation Control Function

■ Easy to read and easy to use, the Slim Smart Remote controls many functions that are beneficial to building management. Air conditioning operation can be limited within a set temperature range, an automatic timer switches the air conditioner off, settings can be displayed in either °C / °F and the Operation Lock feature prevents any random modifications to the setting.

Limiting the set temperature range

Sets upper and lower temperature limits to save energy and prevents excessive heating or cooling.

Auto Off Timer

Reduces wasted energy by turning off the air conditioner automatically. Preset times from 30 minutes to 4 hours in 30-minute increments.

Lock Controller Operation

Disables all buttons or operations on the remote control except for the On/Off button.

Weekly Timer

Remote control includes an embedded weekly timer that allows you to change the temperature to 8 different settings each day.

Setting Example (Restaurant in summer)

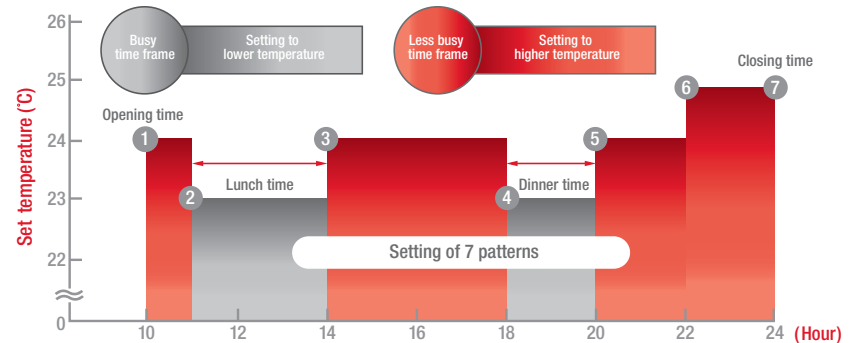

Easy Service and Maintenance Function

With the advanced Mr. Slim A-Control, a simple 3-wire Indoor/Outdoor connecting cable serves as both the indoor power supply and the communication wire that allows for instant system diagnostics, drastically reducing service and maintenance times. This eliminates conventional inspection work such as measuring indoor and outdoor temperatures, as well as the need to remove service panels to measure suction and discharge temperatures.

LOW AMBIENT COOLING

Our Commitment

■ Our 30-year impeccable track record in Canada has made Mitsubishi Electric the trusted name in cold climate equipment room cooling solutions.

Our success is a direct result of our commitment to manufacture the most reliable Low and Ultra Low Ambient systems that are specifically designed for the Canadian climate. All our systems are backed by factory-trained support teams, from corporate to local dealer levels, that are in constant communication with our engineering and support sections in Japan, topped with unmatched parts availability.

More than just a cold climate kit

■ Mitsubishi Electric designs, tests and manufactures our commercial-grade Mr. Slim P-Series Low Ambient and Ultra Low Ambient cooling systems to incorporate the demand for year-long cooling in Canada into the heart of our systems. Microprocessor-control algorithms, refrigerant-control strategies and system operation protection are all factory-designed and integrated as part of our Low and Ultra Low Ambient systems.



Low Ambient Cooling Systems

All P-series Low Ambient cooling systems are designed to perform at -18°C (0°F)



Ultra Low Ambient Cooling Systems

All P-series Ultra Low Ambient cooling systems are designed to perform at -40°C (-40°F)



Available Low and Ultra Low P-Series Systems

System Type	12,000 Btu/h	18,000 Btu/h	24,000 Btu/h	30,000 Btu/h	36,000 Btu/h	42,000 Btu/h
Wall-Mounted (PKA)	yes	yes	yes	yes	yes	yes
Ceiling-Suspended (PCA)			yes	yes	yes	yes
Ceiling Cassette (PLA)	yes	yes	yes	yes	yes	yes
Ceiling-Concealed (PEA/PEAD)	yes	yes	yes	yes	yes	yes

■ P-Series Low and Ultra Low Ambient cooling systems are designed to meet today's demanding commercial cooling environments, such as restaurants, computer and electronic equipment rooms, telecom substations and surveillance mechanical rooms, among others. Optional wind baffle is required.

H²i TURNING UP THE HEAT

Taking comfort to a whole new level

■ Mitsubishi Electric has taken heating to a whole new level with our exclusive patent-pending Hyper-Heat Inverter (H²i™) technology. Even when outdoor temperatures drop to -25°C – levels that would give traditional air-to-air heat pump systems a cold chill – Mr. Slim H²i P-Series ductless heat pumps stay on the job, keeping the indoors at a comfortable and consistent level.

Raising the bar in lower temperatures

■ Heat pump systems deliver a very high COP (coefficient of performance). However, when outdoor temperatures drop, traditional heat pump systems just can't perform. As a result, most applications include a supplemental system to handle heating on days when temperatures fall below 0°C.

Now imagine a way to save on costs by using only a single heat pump system that delivers comfort year-round. That solution is the new Mr. Slim P-Series, featuring our exclusive H²i system, flexible enough for almost any residential, light commercial, or institutional renovation or new construction project. The H²i system delivers high COP in both heating and cooling modes, and that delivers savings benefits all year long.

discharge pressure by using a 2-phase injection compressor. This reduces discharge superheat at high discharge pressure, providing a high COP at lower temperatures without the compressor overheating. The process also increases the system's refrigerant flow rate to provide excellent heating performance at extreme ambient temperatures that conventional heat pumps can't handle. All this means expanded operation at 100% heating capacity when temperatures drop down to -15°C, and 80% heating capacity even when the mercury falls to -25°C.



The secret is our new flash injection process which keeps suction pressure up and maintains high

Performance

■ The H²i system offers a COP of 1.45 at ambient temperatures as low as -25°C, but in fact, such low temperatures generally will not occur on a continual basis. The H²i system also provides excellent COP of up to 3.53 (on PEAD) at higher temperatures, thus providing an extremely high Heating Seasonal Performance Factor (HSPF) over the total operation spectrum, saving energy without sacrificing comfort.

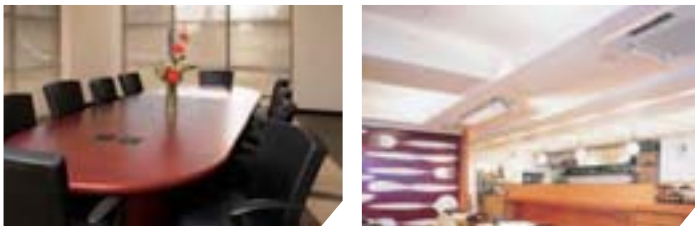

Reliable, easy to install, and extremely quiet, Mr. Slim H²i P-Series is powerful enough for the toughest situations – from boardrooms to conference halls, restaurants and retail locations, where heating and even cooling is needed in extreme weather.



Maximum stable operation

■ The newly designed Flash Injection Circuit provides the optimal amount of refrigerant to the compressor through a specially designed injection port, ensuring stable heating operation without defrost for up to 150 minutes.

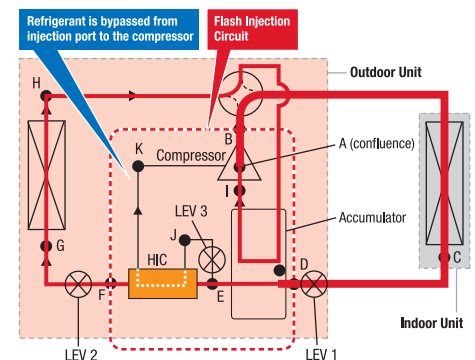

Note: Heat Interchange Circuit (HIC)
Heating efficiency is improved by enhancing the recollection of heat at the outdoor unit with the low temperature refrigerant from the HIC

Plus, the new defrost feature, which prevents

automatic defrosting when not required, gives the system a quick start-up time and continuous heating even in low ambient conditions.

A FORCE OF INNOVATION

CEILING-CONCEALED UNIT

Mr. Slim Ceiling-Concealed Unit

■ Mr. Slim ceiling-concealed unit literally “works behind the scenes” to give you the same comfort and quiet operation as other Mr. Slim units would. With an operating sound of as low as only 23dB (A), the unit is enclosed in the ceiling cavity, leaving only a register and a grille mounted on the ceiling surface to provide airflow. By running short ductworks, the unit can also distribute conditioned air evenly over a large zone or to adjacent rooms. This greatly helps the system to keep the quality of both your comfort and interior decor.

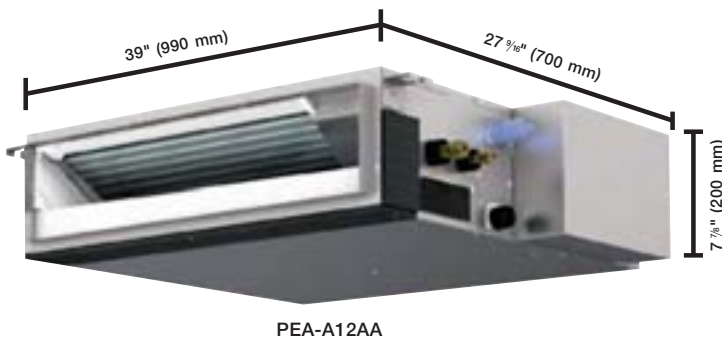

Slim Body

■ The ceiling-concealed units are so slim and compact making installation a breeze. With the smaller capacity PEA units measuring only 7-7/8” high and the larger capacity PEAD units at just 9-7/8” high, these ceiling-concealed units are designed to be flexible for easy installation in tight spaces.

Adjustable Static Pressure

■ A wide range of static pressure settings are available by using the DC fan motor to meet various system configurations and installation conditions, while optimizing comfort levels between sound and air flow.

EXTERNAL STATIC PRESSURE SETTINGS	
PEA-A12/18AA	0.02/0.06/0.14/0.20 in. WG
PEAD-A24/30/36/42AA	0.14/0.20/0.28/0.40/0.60 in. WG

Built-in Drain Pump

■ Ceiling-concealed units come equipped with a high-performance drain pump that is capable of lifting condensation up to 21-11/16 inches above the drain pan. The unit’s fail-safe mechanism recognizes when there is a high level of water in the condensate pan and shuts off the indoor fan and outdoor unit compressor to prevent overflow.

Rotation, Backup, Standby — ALL-IN-ONE

■ P-Series is exceptionally reliable and offers an optimum product life cycle with this new built-in function. Two systems work together in an alternating pattern to ensure both systems share the same amount of operation hours.

Should the demand exceed the capacity of the operating system, the second system which is in standby mode, will start to increase the total capacity and return to standby mode when the demand reduces.

In addition, if an error occurs to the operating unit, the second system will start automatically as a backup, without causing any interruption to the service. (This function is not available in the PEA-Series).

Indoor Unit

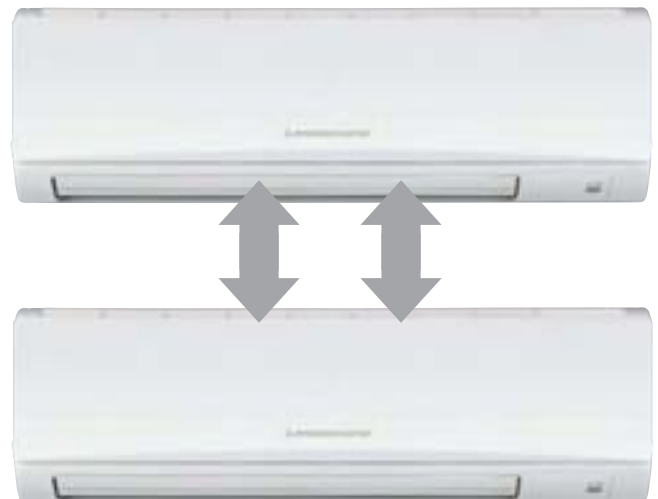

Indoor Unit

i-see Sensor - Maintain an Even Temperature While Reducing Energy Consumption

■ The “i-See Sensor” uses an exclusive new temperature sensing technology, developed by Mitsubishi Electric, to create a comfortable environment in shops and offices. In these applications, it is essential to control the temperature near the floor where occupants and visitors gather. The “i-See Sensor” measures the infra-red rays generated from the surrounding wall and floor surfaces at 360°. These temperature values are then used to determine which parts of the room, distant or nearby, need additional heating or cooling, thus maintaining a constant and even temperature throughout the interior space while reducing overall energy consumption. The “i-See Sensor” is offered as an option on PLA & PCA units.

■ The “i-See Sensor” rotates slowly in intervals of 5 seconds, correctly measuring the temperature of the entire floor space.

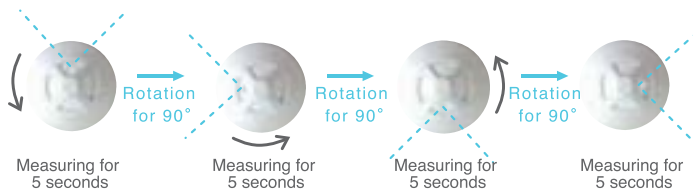

The “i-See Sensor” rotates to measure the floor temperature

“Sensible Temperature Control” to Prevent Excessive Cooling and Heating

By measuring the inlet temperature and floor temperature, a temperature felt by the human body (sensible temperature) can be calculated and maintained, suppressing excessive cooling and heating.

Life without “i-See Sensor”

■ Conventional air conditioning applications in shops and offices only measure temperatures near the ceiling, allowing for an uneven temperature distribution between the ceiling and the floor. If the floor level temperature is left unchecked, the set temperature tends to be higher in order to obtain comfort at floor level, resulting in wasted energy.

Without “i-See Sensor”

Set temperature is 23°C (in Heating)

e.g. To achieve a sensible temperature of 20°C, the set temperature must be as high as 23°C.

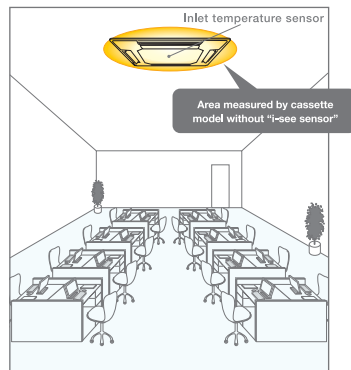
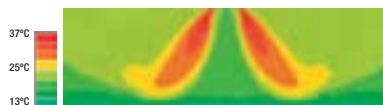

Realize the Power of “i-See Sensor”

■ The new 4-Way Ceiling Cassette with the “i-See Sensor” simultaneously measures the floor and inlet temperatures, providing improved comfort to occupants at floor level and throughout the space while providing increased energy savings.

With the “i-See Sensor” plus automatic airflow adjustment mode

Set temperature is 20°C (in Heating)

e.g. With the set temperature at 20°C, a sensible temperature of 20°C at floor level can be obtained.

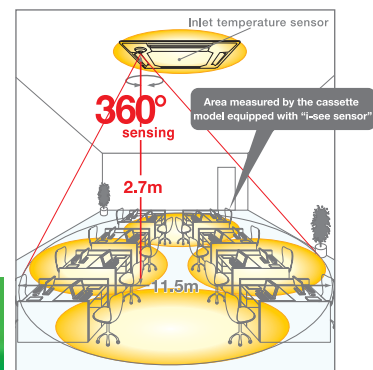



Mr. SLIM™

H²i Hyper Heat Inverter



HEAT PUMP



PKA-A30/36KA

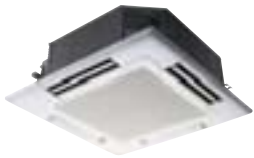

PLA-A30/36BA



Slim Smart Remote



Outdoor unit
PUZ-HA30/36NHA2

- Variable Compressor Speed Inverter Technology
- 80% Heating Capacity at -25°C
- Ozone-Friendly R-410A Refrigerant
- Super-Quiet Technology Only 28dB(A)
- Hot Start System to Provide Warmth in the Beginning
- Ultra-Long Pipe Length - up to 245 ft.
- Refrigerant Pre-Charged
- Hyper-Heat Inverter (H²i) Technology
- Lead-Lag Control Function
- Extremely High Heating Performance

Indoor Unit Model		Outdoor Unit Model		PLA-A30BA PUZ-HA30NHA2	PLA-A36BA PUZ-HA36NHA2	PKA-A30KA PUZ-HA30NHA2
Capacity (Min ~ Max)	Cooling	Btu/h		18,000 - 30,000	18,000 - 36,000	18,000 - 30,000
	Heating	Btu/h		18,000 - 34,000	18,000 - 40,000	18,000 - 34,000
Power Input	Cooling	W		2,450	2,690	2,500
	Heating	W		3,440	3,230	2,930
SEER	Cooling			15.6	17.0	16.5
EER	Cooling			12.2	12.6	12.0
HSPF	Heating			9.4	10.0	9.5
Capacity Control				Variable Compressor Speed	Variable Compressor Speed	Variable Compressor Speed
Refrigerant				R-410A	R-410A	R-410A
Power Supply	V, Phase, Hz			208-230, 1, 60	208-230, 1, 60	208-230, 1, 60
Indoor	Dimension (W x D x H)	inch		33 1/6 x 33 1/6 x 10 3/8	33 1/6 x 33 1/6 x 11 3/4	46 1/6 x 11 5/8 x 14 3/8
		mm		840 x 840 x 258	840 x 840 x 298	1170 x 295 x 365
	Weight	lbs (kg)		51 (23)	55 (25)	46 (21)
	Airflow	CFM Dry		490-570-640-740	710-810-920-1060	635-705-775
	Moisture Removal	Pints/h		7.2	7.1	8.1
	Sound	dB(A)		28-30-32-34	32-34-37-40	39-42-45
	Max. Fuse	A		15	15	15
	Min. Ampacity	A		1	2	1
	Field Drain Pipe Size	in. (mm)		O.D. 1 1/4 (32)	O.D. 1 1/4 (32)	I.D. 3/4 (16)
Outdoor	Dimension (W x D x H)	inch		37 3/8 x 13 x 53 1/2	37 3/8 x 13 x 53 1/2	37 3/8 x 13 x 53 1/2
		mm		950 x 330 x 1350	950 x 330 x 1350	950 x 330 x 1350
	Weight	lbs (kg)		265 (120)	265 (120)	265 (120)
	Sound (Cool/Heat)	dB(A)		52/53	52/53	52/53
	Max. Fuse	A		40	40	40
	Min. Ampacity	A		28	28	28
Pipe Size	Liq. x Gas	in. (mm)		3/8 x 3/8 (9.52 x 15.88)	3/8 x 3/8 (9.52 x 15.88)	3/8 x 3/8 (9.52 x 15.88)
Max. Height Difference		Ft. (m)		100 (30)	100 (30)	100 (30)
Max. Pipe Length		Ft. (m)		245 (75)	245 (75)	245 (75)



PEAD-A30/36AA



PCA-A30/36KA

- Super-Efficient Operation - COP of up to 3.53
- Easy Maintenance with Self-Diagnostic Feature
- Auto-Restart after Power Failure
- Auto Change Over between Cooling & Heating
- Weekly Timer - up to 8 Patterns Each Day
- External Heater Interlock Function
- 2-Year Parts Warranty
- 5-Year Compressor Warranty

PKA-A36KA PUZ-HA36NHA2	PCA-A30KA PUZ-HA30NHA2	PCA-A36KA PUZ-HA36NHA2	PEA-A18AA x2 PUZ-HA36NHA2	PEAD-A30AA PUZ-HA30NHA2	PEAD-A36AA PUZ-HA36NHA2
18,000 - 34,200	18,000 - 30,000	18,000 - 36,000	18,000 - 36,000	18,000 - 30,000	18,000 - 36,000
18,000 - 40,000	18,000 - 34,000	18,000 - 40,000	18,000 - 40,000	18,000 - 34,000	18,000 - 40,000
2,790	2,480	2,810	2,700	2,500	2,800
3,410	2,990	3,270	3,150	2,750	3,150
16.2	16.1	16.6	16.8	16.5	16.8
12.0	12.1	12.1	12.5	12.0	12.1
10.0	9.3	10.3	10.4	9.5	10.4
Variable Compressor Speed	Variable Compressor Speed	Variable Compressor Speed	Variable Compressor Speed	Variable Compressor Speed	Variable Compressor Speed
R-410A	R-410A	R-410A	R-410A	R-410A	R-410A
208-230, 1, 60	208-230, 1, 60	208-230, 1, 60	208-230, 1, 60	208-230, 1, 60	208-230, 1, 60
46 1/8 x 11 5/8 x 14 3/8	50 3/8 x 26 3/4 x 9 1/8	63 x 26 3/4 x 9 1/8	46 7/8 x 27 1/8 x 7 3/8	43 5/8 x 28 1/8 x 9 3/8	55 1/8 x 28 1/8 x 9 3/8
1170 x 295 x 365	1280 x 680 x 230	1600 x 680 x 230	1190 x 700 x 200	1100 x 732 x 250	1400 x 732 x 250
46 (21)	71 (32)	79 (36)	60 (27)	73 (33)	91 (41)
705-810-920	565-600-635-705	775-850-920-990	426-529-635	618-742-883	847-1024-1201
8.7	8.3	8.2	6.7	8.9	7.3
43-46-49	35-37-39-41	37-39-41-43	30-34-38	30-34-39	33-38-42
15	15	15	15	15	15
1	1	2	2	2.73	3.30
I.D. 3/4 (16)	O.D. 1 1/2 (26)	O.D. 1 1/2 (26)	1 1/4 (32)	1 1/4 (32)	1 1/4 (32)
37 3/8 x 13 x 53 1/8	37 3/8 x 13 x 53 1/8	37 3/8 x 13 x 53 1/8	37 3/8 x 13 x 53 1/8	37 3/8 x 13 x 53 1/8	37 3/8 x 13 x 53 1/8
950 x 330 x 1350	950 x 330 x 1350	950 x 330 x 1350	950 x 330 x 1350	950 x 330 x 1350	950 x 330 x 1350
265 (120)	265 (120)	265 (120)	265 (120)	265 (120)	265 (120)
52/53	52/53	52/53	52/53	52/53	52/53
40	40	40	40	40	40
28	28	28	28	28	28
3/8 x 3/8 (9.52 x 15.88)	3/8 x 3/8 (9.52 x 15.88)	3/8 x 3/8 (9.52 x 15.88)	3/8 x 3/8 (9.52 x 15.88)	3/8 x 3/8 (9.52 x 15.88)	3/8 x 3/8 (9.52 x 15.88)
100 (30)	100 (30)	100 (30)	100 (30)	100 (30)	100 (30)
245 (75)	245 (75)	245 (75)	245 (75)	245 (75)	245 (75)



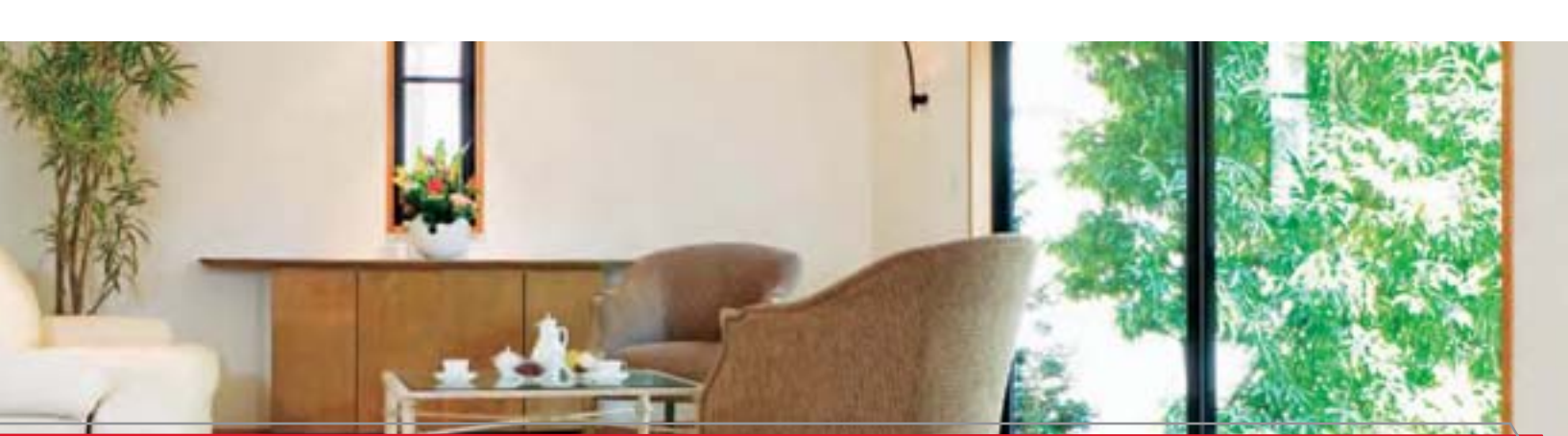

Mr. SLIM™

PEA(D)-SERIES Ceiling-Concealed

COOLING ONLY

- Variable Compressor Speed Inverter Technology
- Ozone-Friendly R-410A Refrigerant
- Significant Energy Savings up to 30%
- Super-Quiet Technology Only 23dB(A)
- Extra-Low Static Pressure of Only 0.02 in.WG
- Easy Maintenance with Self-Diagnostic Feature
- 3 Fan Speed Settings to Deliver Precise Comfort
- Low Ambient Cooling at -18°C (0°F)
- Factory Installed Ultra-Low Ambient (-40°C/F) Option
- Built-in High-Performance Drain Pump
- Auto-Restart after Power Failure
- Extra-Long Pipe Length - up to 165 ft.
- Refrigerant Pre-Charged
- Ultra-Slim Body - less than 8" High
- Weekly Timer - up to 8 Patterns Each Day
- 2-Year Parts Warranty
- 7-Year Compressor Warranty

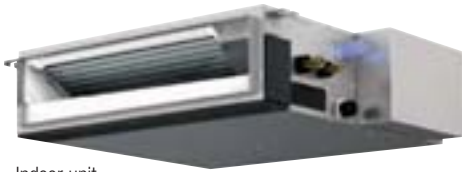

Indoor unit



Slim Smart Remote



Outdoor unit
PUY-A12/18NHA3



Outdoor unit
PUY-A24/30/36NHA3



Outdoor unit
PUY-A42NHA3

Indoor Unit Model		PEA-A12AA	PEA-A18AA	PEAD-A24AA	PEAD-A30AA	PEAD-A36AA	PEAD-A42AA
Outdoor Unit Model		PUY-A12NHA3	PUY-A18NHA3	PUY-A24NHA3	PUY-A30NHA3	PUY-A36NHA3	PUY-A42NHA3
Capacity (Min ~ Max)	Cooling Btu/h	6,000 ~ 12,000	8,000 ~ 18,000	12,000 ~ 24,000	12,000 ~ 30,000	12,000 ~ 35,000	18,000 ~ 42,000
Power Input	Cooling W	1,240	2,150	2,400	3,850	4,850	5,350
SEER		13.8	14.3	16.0	15.5	15.0	13.8
EER		9.7	8.4	10.0	7.7	7.2	7.8
Capacity Control		Variable Compressor Speed					
Refrigerant		R-410A					
Power Supply	V, Phase, Hz	208-230, 1, 60					
Indoor	Dimension (W x D x H)	inch	39 x 27 1/8 x 7 7/8	46 1/2 x 27 3/8 x 7 7/8	43 3/8 x 28 7/8 x 9 7/8		55 1/2 x 28 7/8 x 9 7/8
		mm	990 x 700 x 200	1190 x 700 x 200	1100 x 732 x 250		1400 x 732 x 250
	Weight	lbs (kg)	48 (21)	60 (27)	73 (33)	73 (33)	91 (41) / 95 (43)
	Airflow (Lo-Med-Hi)	CFM Dry	247-317-388	423-529-635	512-636-742	618-742-883	847-1024-1201 / 1042-1254-1483
	Ext. Static Pressure	in. WG	0.02/0.06/0.14/0.20	0.02/0.06/0.14/0.20	0.14/0.20/0.28/0.40/0.60		0.14/0.20/0.28/0.40/0.60
		Pa	5/15/35/50	5/15/35/50	35/50/70/100/150		35/50/70/100/150
	Moisture Removal	Pint/h	2.47	3.26	6.9	8.6	7.9 / 9.0
	Sound (Lo-Med-Hi)	dB(A)	23-28-33	30-34-38	30-33-37	30-34-39	33-38-42 / 36-40-44
	Max. Fuse	A	15	15	15	15	15
	Min. Ampacity	A	1	2	2.63	2.73	3.30 / 3.50
	Field Drain Pipe Size	O.D. in. (mm)	1-1/4 (32)	1-1/4 (32)	1-1/4 (32)	1-1/4 (32)	1 1/2 (32) / 1 1/2 (32)
Outdoor	Dimension (W x D x H)	inch	31 1/2 x 13 x 23 3/4		37 3/4 x 13 x 37 3/4		37 3/4 x 13 x 53 1/4
		mm	800 x 330 x 600		950 x 330 x 943		950 x 330 x 1350
	Weight	lbs (kg)	90 (41)	97 (44)	165 (75)	165 (75)	165 (75) / 260 (118)
	Sound	dB(A)	46	46	48	48	48 / 51
	Max. Fuse	A	15	20	30	40	40
	Min. Ampacity	A	13	13	18	25	25 / 26
Pipe Size	Liq. x Gas in. (mm)		3/4 x 1/2 (6.35 x 12.7)		3/4 x 1/2 (9.52 x 15.88)		
Max. Height Difference	Ft. (m)		100 (30)	100 (30)	100 (30)	100 (30)	100 (30)
Max. Pipe Length	Ft. (m)		100 (30)	100 (30)	165 (50)	165 (50)	165 (50)



Mr. SLIM™

PEA(D)-SERIES Ceiling-Concealed

HEAT PUMP

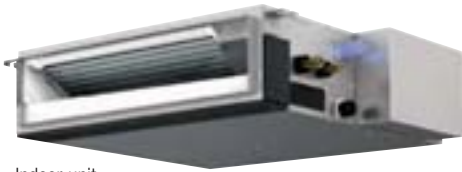

Indoor unit



Slim Smart Remote



Outdoor unit
PUZ-A18NHA3



Outdoor unit
PUZ-A24/30/36NHA3



Outdoor unit
PUZ-A42NHA3

- Variable Compressor Speed Inverter Technology
- Ozone-Friendly R-410A Refrigerant
- Significant Energy Savings up to 30%
- Super-Quiet Technology Only 23dB(A)
- Extra-Low Static Pressure of Only 0.02 in.WG
- Easy Maintenance with Self-Diagnostic Feature
- 3 Fan Speed Settings to Deliver Precise Comfort
- Hot Start System to Provide Warmth in the Beginning
- External Heater Interlock Function
- Auto-Restart after Power Failure
- Built-in High-Performance Drain Pump
- Extra-Long Pipe Length - up to 165 ft.
- Auto Change Over between Cooling & Heating
- Refrigerant Pre-Charged
- Ultra-Slim Body - less than 8" High
- Weekly Timer - up to 8 Patterns Each Day
- 2-Year Parts Warranty
- 7-Year Compressor Warranty

Indoor Unit Model Outdoor Unit Model		PEA-A18AA PUZ-A18NHA3	PEAD-A24AA PUZ-A24NHA3	PEAD-A30AA PUZ-A30NHA3	PEAD-A36AA PUZ-A36NHA3	PEAD-A42AA PUZ-A42NHA3
Capacity (Min ~ Max)	Cooling Btu/h	8,000 ~ 18,000	12,000 ~ 24,000	12,000 ~ 30,000	12,000 ~ 35,000	18,000 ~ 42,000
	Heating Btu/h	8,000 ~ 20,000	12,000 ~ 28,000	12,000 ~ 34,000	12,000 ~ 38,000	18,000 ~ 48,000
Power Input	Cooling W	2,150	2,400	3,850	4,850	5,350
	Heating W	1,540	2,250	2,990	3,290	3,820
SEER	Cooling	14.3	16.0	15.5	15.0	13.8
EER	Cooling	8.4	10.0	7.7	7.2	7.8
HSPF	Heating	10.0	10.2	9.4	9.8	10.0
Capacity Control		Variable Compressor Speed				
Refrigerant		R-410A				
Power Supply	V, Phase, Hz	208-230, 1, 60				
Indoor	Dimension (W x D x H)	inch	46 7/8 x 27 5/8 x 7 7/8	43 5/8 x 28 3/8 x 9 1/8	55 1/8 x 28 3/8 x 9 1/8	
		mm	1190 x 700 x 200	1100 x 732 x 250	1400 x 732 x 250	
	Weight	lbs (kg)	60 (27)	73 (33)	73 (33)	91 (41) / 95 (43)
	Airflow (Lo-Med-Hi)	CFM Dry	423-529-635	512-636-742	618-742-883	847-1024-1201 / 1042-1254-1483
	Ext. Static Pressure	in. WG	0.02/0.06/0.14/0.20	0.14/0.20/0.28/0.40/0.60		0.14/0.20/0.28/0.40/0.60
		Pa	5/15/35/50	35/50/70/100/150		35/50/70/100/150
	Moisture Removal	Pints/h	3.26	6.9	8.6	7.9 / 9.0
	Sound (Lo-Med-Hi)	dB(A)	30-34-38	30-33-37	30-34-39	33-38-42 / 36-40-44
	Max. Fuse	A	15	15	15	15
	Min. Ampacity	A	2	2.63	2.73	3.30 / 3.50
	Field Drain Pipe Size	O.D. in. (mm)	1 1/4 (32)	1 1/4 (32)	1 1/4 (32)	1 1/4 (32)
Outdoor	Dimension (W x D x H)	inch	31-1/2 x 13 x 23-5/8	37-3/8 x 13 x 37-1/8		37-3/8 x 13 x 53-1/8
		mm	800 x 330 x 600	950 x 330 x 943		950 x 330 x 1350
	Weight	lbs (kg)	99 (45)	165 (75)	165 (75)	165 (75) / 260 (118)
	Sound (Cool/Heat)	dB(A)	46/47	48/50	48/50	48/50 / 51/55
	Max. Fuse	A	20	30	40	40
	Min. Ampacity	A	13	18	25	25
Pipe Size	Liq. x Gas in. (mm)	1/4 x 1/2 (6.35 x 12.7)		3/8 x 5/8 (9.52 x 15.88)		
Max. Height Difference	Ft. (m)	100 (30)		100 (30)	100 (30)	100 (30)
Max. Pipe Length	Ft. (m)	100 (30)		165 (50)	165 (50)	165 (50)



MITSUBISHI ELECTRIC
Changes for the Better

All test conditions are based on ARI 210/240.

Rating conditions: Cooling — Indoor: D.B. 26.7°C (80°F), W.B. 19.4°C (67°F); Outdoor: D.B. 35.0°C (95°F), W.B. 23.9°C (75°F)
Heating — Indoor: D.B. 21.1°C (70°F), W.B. 15.6°C (60°F); Outdoor: D.B. 8.3°C (47°F), W.B. 6.1°C (43°F)



Mr. SLIM™

PCA-SERIES Ceiling-Suspended

COOLING ONLY



Indoor unit



Slim Smart Remote



Outdoor unit
PUY-A24/30/36NHA3



Outdoor unit
PUY-A42NHA3

- Variable Compressor Speed Inverter Technology
- Ozone-Friendly R-410A Refrigerant
- Significant Energy Savings up to 30%
- Super-Quiet Technology
- Easy Maintenance with Self-Diagnostic Feature
- Auto Vane & Swing Mode with 4-Notch Fan Speeds
- Auto Restart after Power Failure
- Low Ambient Cooling at -18°C (0°F)
- Factory Installed Ultra-Low Ambient (-40°C/F) Option
- Lead-Lag and Backup Function
- i-See Sensor (optional)
- High-Performance Drain Pump (optional)
- Extra-Long Pipe Length - up to 165 ft.
- Refrigerant Pre-Charged
- Easy Installation - No Ductwork Needed
- Weekly Timer - up to 8 Patterns Each Day
- 2-Year Parts Warranty
- 7-Year Compressor Warranty

Indoor Unit Model		Outdoor Unit Model		PCA-A24KA PUY-A24NHA3	PCA-A30KA PUY-A30NHA3	PCA-A36KA PUY-A36NHA3	PCA-A42KA PUY-A42NHA3
Capacity (Min ~ Max)	Cooling	Btu/h	12,000 ~ 24,000	12,000 ~ 30,000	12,000 ~ 35,000	18,000 ~ 42,000	
Power Input	Cooling	W	2,340	3,760	4,630	4,110	
SEER			16.8	14.5	14.4	15.8	
EER			10.3	8.0	7.6	10.2	
Capacity Control	Variable Compressor Speed						
Refrigerant	R-410A						
Power Supply	V, Phase, Hz		208-230, 1, 60				
Indoor	Dimension (W x D x H)	inch	50 3/4 x 26 3/4 x 9 1/8			63 x 26 3/4 x 9 1/8	
		mm	1,280 x 680 x 230			1,600 x 680 x 230	
	Weight	lbs (kg)	71 (32)	71 (32)	76 (36)	84 (38)	
	Airflow (Lo-M2-M1-Hi)	CFM Dry	560-565-600-670	565-600-635-705	775-850-920-990	810-885-955-1025	
	Moisture Removal	Pints/h	5.8	8.3	8.5	11.7	
	Sound (Lo-M2-M1-Hi)	dB(A)	33-35-37-40	35-37-39-41	37-39-41-43	39-41-43-45	
	Max. Fuse	A	15	15	15	15	
	Min. Ampacity	A	1	1	2	2	
	Field Drain Pipe Size	O.D. in. (mm)	1 1/2 (26)	1 1/2 (26)	1 1/2 (26)	1 1/2 (26)	
Outdoor	Dimension (W x D x H)	inch	37 3/8 x 13 x 37 3/8			37 3/8 x 13 x 53 3/8	
		mm	950 x 330 x 943			950 x 330 x 1,350	
	Weight	lbs (kg)	163 (74)	163 (74)	163 (74)	258 (117)	
	Sound	dB(A)	48	48	48	51	
	Max. Fuse	A	30	40	40	40	
	Min. Ampacity	A	18	25	25	26	
Pipe Size	Liq. x Gas in. (mm)		3/8 x 3/8 (9.52 x 15.88)				
Max. Height Difference	Ft. (m)		100 (30)	100 (30)	100 (30)	100 (30)	
Max. Pipe Length	Ft. (m)		165 (50)	165 (50)	165 (50)	165 (50)	



Mr. SLIM™

PCA-SERIES Ceiling-Suspended

HEAT PUMP



Indoor unit



Slim Smart Remote



Outdoor unit
PUZ-A24/30/36NHA3



Outdoor unit
PUZ-A42NHA3

- Variable Compressor Speed Inverter Technology
- Ozone-Friendly R-410A Refrigerant
- Significant Energy Savings up to 30%
- Super-Quiet Technology
- Auto Change Over between Cooling & Heating
- Easy Maintenance with Self-Diagnostic Feature
- Auto Vane & Swing Mode with 4-Notch Fan Speeds
- Hot Start System to Provide Warmth in the Beginning
- External Heater Interlock Function
- Lead-Lag and Backup Function
- i-See Sensor (optional)
- Auto Restart after Power Failure
- High-Performance Drain Pump (optional)
- Extra-Long Pipe Length - up to 165 ft.
- Refrigerant Pre-Charged
- Easy Installation - No Ductwork Needed
- Weekly Timer - up to 8 Patterns Each Day
- 2-Year Parts Warranty
- 7-Year Compressor Warranty

Indoor Unit Model		Outdoor Unit Model		PCA-A24KA PUZ-A24NHA3	PCA-A30KA PUZ-A30NHA3	PCA-A36KA PUZ-A36NHA3	PCA-A42KA PUZ-A42NHA3
Capacity (Min ~ Max)	Cooling	Btu/h	12,000 ~ 24,000	12,000 ~ 30,000	12,000 ~ 35,000	18,000 ~ 42,000	
	Heating	Btu/h	12,000 ~ 28,000	12,000 ~ 34,000	12,000 ~ 38,000	18,000 ~ 48,000	
Power Input	Cooling	W	2,340	3,760	4,630	4,110	
	Heating	W	2,310	3,210	3,190	3,830	
SEER	Cooling		16.8	14.5	14.4	15.8	
EER	Cooling		10.3	8.0	7.6	10.2	
HSPF	Heating		10.9	9.2	10.2	10.2	
Capacity Control	Variable Compressor Speed						
Refrigerant	R-410A						
Power Supply	V, Phase, Hz		208-230, 1, 60				
Indoor	Dimension (W x D x H)	inch	50 3/8 x 26 3/4 x 9 1/8			63 x 26 3/4 x 9 1/8	
		mm	1,280 x 680 x 230			1,600 x 680 x 230	
	Weight	lbs (kg)	71 (32)	71 (32)	76 (36)	84 (38)	
	Airflow (Lo-M2-M1-Hi)	CFM Dry	560-565-600-670	565-600-635-705	775-850-920-990	810-885-955-1025	
	Moisture Removal	Pints/h	5.8	8.3	8.5	11.7	
	Sound (Lo-M2-M1-Hi)	dB(A)	33-35-37-40	35-37-39-41	37-39-41-43	39-41-43-45	
	Max. Fuse	A	15	15	15	15	
	Min. Ampacity	A	1	1	2	2	
	Field Drain Pipe Size	O.D. in. (mm)	1 1/2 (26)	1 1/2 (26)	1 1/2 (26)	1 1/2 (26)	
Outdoor	Dimension (W x D x H)	inch	37 3/8 x 13 x 37 1/8			37 3/8 x 13 x 53 1/8	
		mm	950 x 330 x 943			950 x 330 x 1,350	
	Weight	lbs (kg)	165 (75)	165 (75)	165 (75)	260 (118)	
	Sound (Cool/Heat)	dB(A)	48/50	48/50	48/50	51/55	
	Max. Fuse	A	30	40	40	40	
	Min. Ampacity	A	18	25	25	26	
Pipe Size	Liq. x Gas in. (mm)		3/8 x 3/8 (9.52 x 15.88)				
Max. Height Difference	Ft. (m)		100 (30)	100 (30)	100 (30)	100 (30)	
Max. Pipe Length	Ft. (m)		165 (50)	165 (50)	165 (50)	165 (50)	



All test conditions are based on ARI 210/240.
 Rating conditions: Cooling — Indoor: D.B. 26.7°C (80°F), W.B. 19.4°C (67°F); Outdoor: D.B. 35.0°C (95°F), W.B. 23.9°C (75°F)
 Heating — Indoor: D.B. 21.1°C (70°F), W.B. 15.6°C (60°F); Outdoor: D.B. 8.3°C (47°F), W.B. 6.1°C (43°F)



PKA-SERIES Wall-Mounted

COOLING ONLY

- Variable Compressor Speed Inverter Technology
- Ozone-Friendly R-410A Refrigerant
- Significant Energy Savings up to 30%
- Super-Quiet Technology
- Easy Maintenance with Self-Diagnostic Feature
- Auto Vane & Swing Mode with 3-Notch Fan Speeds
- Auto Restart after Power Failure
- Low Ambient Cooling at -18°C (0°F)
- Factory Installed Ultra-Low Ambient (-40°C/F) Option
- Lead-Lag and Backup Function
- High-Performance Drain Pump (optional)
- Extra-Long Pipe Length - up to 165 ft.
- Refrigerant Pre-Charged
- Easy Installation - No Ductwork Needed
- Weekly Timer - up to 8 Patterns Each Day
- 2-Year Parts Warranty
- 7-Year Compressor Warranty



Indoor unit
PKA-A12/18HA



Indoor unit
PKA-A24/30/36KA



Slim Smart Remote



Outdoor unit
PUY-A12/18NHA3



Outdoor unit
PUY-A24/30/36NHA3

Indoor Unit Model		PKA-A12HA	PKA-A18HA	PKA-A24KA	PKA-A30KA	PKA-A36KA
Outdoor Unit Model		PUY-A12NHA3	PUY-A18NHA3	PUY-A24NHA3	PUY-A30NHA3	PUY-A36NHA3
Capacity (Min ~ Max)	Cooling Btu/h	6,000 ~ 12,000	8,000 ~ 18,000	12,000 ~ 24,000	12,000 ~ 30,000	12,000 ~ 34,200
Power Input	Cooling W	1,190	2,240	2,270	4,130	5,030
SEER		15.2	15.3	17.0	15.5	14.0
EER		10.1	8.0	10.6	7.3	6.8
Capacity Control		Variable Compressor Speed				
Refrigerant		R-410A				
Power Supply	V, Phase, Hz	208-230, 1, 60				
Indoor	Dimension	35 3/8 x 9 13/16 x 11 5/8			46 1/16 x 11 5/8 x 14 3/8	
	(W x D x H)	898 x 249 x 295			1170 x 295 x 365	
	Weight	29 (13)	29 (13)	46 (21)	46 (21)	46 (21)
	Airflow (Lo-Med-Hi)	CFM Dry	320-370-425	320-370-425	635-705-775	635-705-775
	Moisture Removal	Pints/h	2.0	5.2	5.0	8.1
	Sound (Lo-Med-Hi)	dB(A)	36-40-43	36-40-43	39-42-45	39-42-45
	Max. Fuse	A	15	15	15	15
	Min. Ampacity	A	1	1	1	1
	Field Drain Pipe Size	I.D. in. (mm)	5/8 (16)	5/8 (16)	5/8 (16)	5/8 (16)
Outdoor	Dimension	31 1/2 x 13 x 23 5/8			37 3/8 x 13 x 37 1/8	
	(W x D x H)	800 x 330 x 600			950 x 330 x 943	
	Weight	lbs (kg)	90 (41)	97 (44)	163 (74)	163 (74)
	Sound	dB(A)	46	46	48	48
	Max. Fuse	A	15	20	30	40
	Min. Ampacity	A	13	13	18	25
Pipe Size	Liq. x Gas in. (mm)	1/4 x 1/2 (6.35 x 12.7)			3/8 x 3/8 (9.52 x 15.88)	
Max. Height Difference	Ft. (m)	100 (30)	100 (30)	100 (30)	100 (30)	100 (30)
Max. Pipe Length	Ft. (m)	100 (30)	100 (30)	165 (50)	165 (50)	165 (50)



Mr. SLIM™

PKA-SERIES Wall-Mounted

HEAT PUMP

- Variable Compressor Speed Inverter Technology
- Ozone-Friendly R-410A Refrigerant
- Significant Energy Savings up to 30%
- Super-Quiet Technology
- Auto Change Over between Cooling & Heating
- Easy Maintenance with Self-Diagnostic Feature
- Auto Vane & Swing Mode with 3-Notch Fan Speeds
- Hot Start System to Provide Warmth in the Beginning
- External Heater Interlock Function
- Lead-Lag and Backup Function
- Auto Restart after Power Failure
- High-Performance Drain Pump (optional)
- Extra-Long Pipe Length - up to 165 ft.
- Refrigerant Pre-Charged
- Easy Installation - No Ductwork Needed
- Weekly Timer - up to 8 Patterns Each Day
- 2-Year Parts Warranty
- 7-Year Compressor Warranty



Indoor unit
PKA-A18HA



Indoor unit
PKA-A24/30/36KA



Slim Smart Remote



Outdoor unit
PUZ-A18NHA3



Outdoor unit
PUZ-A24/30/36NHA3

Indoor Unit Model		Outdoor Unit Model		PKA-A18HA PUZ-A18NHA3	PKA-A24KA PUZ-A24NHA3	PKA-A30KA PUZ-A30NHA3	PKA-A36KA PUZ-A36NHA3
Capacity (Min ~ Max)	Cooling	Btu/h	8,000 ~ 18,000	12,000 ~ 24,000	12,000 ~ 30,000	12,000 ~ 34,200	
	Heating	Btu/h	8,000 ~ 20,000	12,000 ~ 28,000	12,000 ~ 34,000	12,000 ~ 38,000	
Power Input	Cooling	W	2,240	2,270	4,130	5,030	
	Heating	W	1,970	2,330	3,150	3,610	
SEER	Cooling		15.3	17.0	15.5	14.0	
EER	Cooling		8.0	10.6	7.3	6.8	
HSPF	Heating		9.5	10.8	8.9	9.3	
Capacity Control	Variable Compressor Speed						
Refrigerant	R-410A						
Power Supply	V, Phase, Hz		208-230, 1, 60				
Indoor	Dimension (W x D x H)	inch	35 3/8 x 9 13/16 x 11 5/8		46 1/8 x 11 5/8 x 14 3/8		
		mm	898 x 249 x 295		1170 x 295 x 365		
	Weight	lbs (kg)	29 (13)	46 (21)	46 (21)	46 (21)	
	Airflow (Lo-Med-Hi)	CFM Dry	320-370-425	635-705-775	635-705-775	705-810-920	
	Moisture Removal	Pints/h	5.2	5.0	8.1	9.2	
	Sound (Lo-Med-Hi)	dB(A)	36-40-43	39-42-45	39-42-45	43-46-49	
	Max. Fuse	A	15	15	15	15	
	Min. Ampacity	A	1	1	1	1	
	Field Drain Pipe Size	I.D. in. (mm)	5/8 (16)	5/8 (16)	5/8 (16)	5/8 (16)	
Outdoor	Dimension (W x D x H)	inch	31 1/2 x 13 x 23 5/8		37 3/8 x 13 x 37 1/8		
		mm	800 x 330 x 600		950 x 330 x 943		
	Weight	lbs (kg)	99 (45)	165 (75)	165 (75)	165 (75)	
	Sound (Cool/Heat)	dB(A)	46/47	48/50	48/50	48/50	
	Max. Fuse	A	20	30	40	40	
	Min. Ampacity	A	13	18	25	25	
Pipe Size	Liq. x Gas in. (mm)		1/4 x 1/2 (6.35 x 12.7)		3/8 x 3/8 (9.52 x 15.88)		
Max. Height Difference	Ft. (m)		100 (30)	100 (30)	100 (30)	100 (30)	
Max. Pipe Length	Ft. (m)		100 (30)	165 (50)	165 (50)	165 (50)	



Changes for the Better

All test conditions are based on ARI 210/240.

Rating conditions: Cooling — Indoor: D.B. 26.7°C (80°F), W.B. 19.4°C (67°F); Outdoor: D.B. 35.0°C (95°F), W.B. 23.9°C (75°F)
Heating — Indoor: D.B. 21.1°C (70°F), W.B. 15.6°C (60°F); Outdoor: D.B. 8.3°C (47°F), W.B. 6.1°C (43°F)



PLA-SERIES 4-Way Ceiling Cassette

COOLING ONLY

- Variable Compressor Speed Inverter Technology
- Ozone-Friendly R-410A Refrigerant
- Significant Energy Savings up to 30%
- Super-Quiet Technology Only 27dB(A)
- Easy Maintenance with Self-Diagnostic Feature
- 72 Airflow Patterns with 4-Notch Fan Speeds
- Auto Restart after Power Failure
- Low Ambient Cooling at -18°C (0°F)
- Factory Installed Ultra-Low Ambient (-40°C/F) Option
- Lead-Lag and Backup Function
- i-See Sensor (optional)
- Built-in High Performance Drain Pump
- Extra-Long Pipe Length - up to 165 ft.
- Refrigerant Pre-Charged
- Easy Installation - No Ductwork Needed
- Handy Corner Pocket for Ease of Installation and Service
- Weekly Timer - up to 8 Patterns Each Day
- 2-Year Parts Warranty
- 7-Year Compressor Warranty



Indoor unit



Slim Smart Remote



Outdoor unit
PUY-A12/18NHA3



Outdoor unit
PUY-A24/30/36NHA3



Outdoor unit
PUY-A42NHA3

Indoor Unit Model			PLA-A12BA	PLA-A18BA	PLA-A24BA	PLA-A30BA	PLA-A36BA	PLA-A42BA
Outdoor Unit Model			PUY-A12NHA3	PUY-A18NHA3	PUY-A24NHA3	PUY-A30NHA3	PUY-A36NHA3	PUY-A42NHA3
Capacity (Min ~ Max)	Cooling	Btu/h	6,000 ~ 12,000	8,000 ~ 18,000	12,000 ~ 24,000	12,000 ~ 30,000	12,000 ~ 35,000	18,000 ~ 42,000
Power Input	Cooling	W	1,260	1,940	2,500	4,100	4,500	4,600
SEER			13.5	14.2	13.6	13.6	14.2	14.4
EER			9.5	9.3	9.6	7.3	7.8	9.1
Capacity Control			Variable Compressor Speed					
Refrigerant			R-410A					
Power Supply		V, Phase, Hz	208-230, 1, 60					
Indoor	Dimension (W x D x H)	inch	33 1/8 x 33 1/8 x 10 3/8				33 1/8 x 33 1/8 x 11 1/8	
		mm	840 x 840 x 258				840 x 840 x 298	
	Weight	lbs (kg)	49 (22)	49 (22)	51 (23)	51 (23)	55 (25)	55 (25)
	Airflow (Lo-M2-M1-Hi)	CFM Dry	390-420-460-530	420-490-570-640	420-490-570-640	490-570-640-740	710-810-920-1060	780-880-990-1090
	Moisture Removal	Pints/h	1.7	3.0	5.1	7.2	8.1	10.9
Sound (Lo-M2-M1-Hi)	dB(A)		27-28-29-31	28-29-31-32	28-29-31-32	28-30-32-34	32-34-37-40	34-36-39-41
		Max. Fuse	A	15	15	15	15	15
	Min. Ampacity	A	1	1	1	1	2	
	Field Drain Pipe Size	O.D. in. (mm)	1 1/4 (32)	1 1/4 (32)	1 1/4 (32)	1 1/4 (32)	1 1/4 (32)	1 1/4 (32)
Outdoor	Dimension (W x D x H)	inch	31 1/2 x 13 x 23 3/8			37 3/8 x 13 x 37 3/8		37 3/8 x 13 x 53 3/8
		mm	800 x 330 x 600			950 x 330 x 943		950 x 330 x 1,350
	Weight	lbs (kg)	90 (41)	97 (44)	163 (74)	163 (74)	163 (74)	258 (117)
	Sound	dB(A)	46	46	48	48	48	51
	Max. Fuse	A	15	20	30	40	40	40
	Min. Ampacity	A	13	13	18	25	25	26
Pipe Size		Liq. x Gas in. (mm)	3/4 x 1/2 (6.35 x 12.7)			3/8 x 3/8 (9.52 x 15.88)		
Max. Height Difference		Ft. (m)	100 (30)	100 (30)	100 (30)	100 (30)	100 (30)	100 (30)
Max. Pipe Length		Ft. (m)	100 (30)	100 (30)	165 (50)	165 (50)	165 (50)	165 (50)



Mr. SLIM™

PLA-SERIES 4-Way Ceiling Cassette

HEAT PUMP

- Variable Compressor Speed Inverter Technology
- Ozone-Friendly R-410A Refrigerant
- Significant Energy Savings up to 30%
- Super-Quiet Technology Only 27db(A)
- Easy Maintenance with Self-Diagnostic Feature
- 72 Airflow Patterns with 4-Notch Fan Speeds
- Auto-Restart after Power Failure
- Lead-Lag Control Function
- External Heater Interlock Function
- i-See Sensor (optional)
- Built-in High-Performance Drain Pump
- Extra-Long Pipe Length - up to 165 ft.
- Refrigerant Pre-Charged
- Easy Installation - No Ductwork Needed
- Handy Corner Pocket for Ease of Installation and Service
- Weekly Timer - up to 8 Patterns Each Day
- 2-Year Parts Warranty
- 7-Year Compressor Warranty



Indoor unit



Slim Smart Remote



Outdoor unit
PUZ-A18NHA3



Outdoor unit
PUZ-A24/30/36NHA3



Outdoor unit
PUZ-A42NHA3

Indoor Unit Model		PLA-A18BA	PLA-A24BA	PLA-A30BA	PLA-A36BA	PLA-A42BA
Outdoor Unit Model		PUZ-A18NHA3	PUZ-A24NHA3	PUZ-A30NHA3	PUZ-A36NHA3	PUZ-A42NHA3
Capacity (Min ~ Max)	Cooling Btu/h	8,000 ~ 18,000	12,000 ~ 24,000	12,000 ~ 30,000	12,000 ~ 35,000	18,000 ~ 42,000
	Heating Btu/h	8,000 ~ 20,000	12,000 ~ 28,000	12,000 ~ 34,000	12,000 ~ 38,000	18,000 ~ 48,000
Power Input	Cooling W	1,940	2,500	4,100	4,500	4,600
	Heating W	1,900	2,570	3,370	3,300	4,450
SEER	Cooling	14.2	13.6	13.6	14.2	14.4
EER	Cooling	9.3	9.6	7.3	7.8	9.1
HSPF	Heating	9.8	8.5	8.7	9.3	9.3
Capacity Control		Variable Compressor Speed				
Refrigerant		R-410A				
Power Supply	V, Phase, Hz	208-230, 1, 60				
Indoor	Dimension (W x D x H)	33 1/8 x 33 1/8 x 10 3/8			33 1/8 x 33 1/8 x 11 3/8	
		840 x 840 x 258			840 x 840 x 298	
	Weight	49 (22)	51 (23)	51 (23)	55 (25)	55 (25)
	Airflow (Lo-M2-M1-Hi)	CFM Dry	420-490-570-640	420-490-570-640	490-570-640-740	710-810-920-1060
	Moisture Removal	Pints/h	3.0	5.1	7.2	8.1
	Sound (Lo-M2-M1-Hi)	dB(A)	28-29-31-32	28-29-31-32	28-30-32-34	32-34-37-40
	Max. Fuse	A	15	15	15	15
	Min. Ampacity	A	1	1	1	2
	Field Drain Pipe Size	O.D. in. (mm)	1 1/4 (32)	1 1/4 (32)	1 1/4 (32)	1 1/4 (32)
Outdoor	Dimension (W x D x H)	31 1/2 x 13 x 23 3/8		37 3/8 x 13 x 37 1/8		
		800 x 330 x 600		950 x 330 x 943		
	Weight	99 (45)	165 (75)	165 (75)	165 (75)	260 (118)
	Sound (Cool/Heat)	dB(A)	46/47	48/50	48/50	48/50
	Max. Fuse	A	20	30	40	40
	Min. Ampacity	A	13	18	25	26
Pipe Size	Liq. x Gas in. (mm)	1/4 x 1/2 (6.35 x 12.7)		3/8 x 3/8 (9.52 x 15.88)		
Max. Height Difference	Ft. (m)	100 (30)	100 (30)	100 (30)	100 (30)	100 (30)
Max. Pipe Length	Ft. (m)	100 (30)	165 (50)	165 (50)	165 (50)	165 (50)



Changes for the Better





All test conditions are based on ARI 210/240.

Rating conditions: Cooling — Indoor: D.B. 26.7°C (80°F), W.B. 19.4°C (67°F); Outdoor: D.B. 35.0°C (95°F), W.B. 23.9°C (75°F)
 Heating — Indoor: D.B. 21.1°C (70°F), W.B. 15.6°C (60°F); Outdoor: D.B. 8.3°C (47°F), W.B. 6.1°C (43°F)

A FLEXIBLE LINEUP

■ The compact design of the P-Series makes cooling and heating difficult spaces a breeze. With wall-mounted, ceiling-recessed, ceiling-suspended, and ceiling-concealed options, the P-Series is the perfect solution for almost any commercial or large residential application.

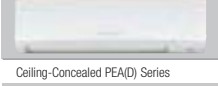
Mr. Slim P-Series units deliver flexible and convenient cooling and heating solutions of up to 42,000 BTU/h.

Model Name		12kBTU/h	18kBTU/h	24kBTU/h	30kBTU/h	36kBTU/h	42kBTU/h
 4-way Cassette PLA Series	Cooling	●	●	●	●	●	●
	Heating		●	●	●*	●*	●
 Ceiling-Suspended PCA Series	Cooling			●	●	●	●
	Heating			●	●*	●*	●
 Wall-Mounted PKA-HA Series	Cooling	●	●				
	Heating		●				
 Wall-Mounted PKA-KA Series	Cooling			●	●	●	
	Heating			●	●*	●*	
 Ceiling-Concealed PEA(D) Series	Cooling	●	●	●	●	●	●
	Heating		●*	●	●*	●*	●

*Available with Hyper Heat Inverter (H²) Heat Pump System

■ Mitsubishi Electric Quality marks over 80 years of excellence in technology, design and manufacturing, representing the highest standards of comfort, durability and efficiency.



Our quality assurance program is guided by our stringent Quality Policy, which ensures that all phases of the development process – from design and manufacture to the finished product – must meet our standards.

What it means to you is that Mitsubishi Electric simply makes the best air conditioners that you can buy today.

COMFORT	DURABILITY	EFFICIENCY
Quiet operation	Strict performance tests	Energy saving
Optimal temperature distribution	Easy-to-clean design	Money saving
Clean, filtered air	Replacement parts available	Space saving



Line Test



Sound Test



Performance Test



Endurance Test



Heat Stress Test



Saltwater Spray Rust Test



COMFORTING EXPERIENCE

Mitsubishi Electric Canada

■ Mitsubishi Electric Sales Canada Inc. was established in 1979 as a subsidiary of the Mitsubishi Electric Corporation of Japan. Since then Mitsubishi Electric Sales Canada Inc. has been at the forefront of heating and air conditioning technology, sales, installation and service.

With 80 years of experience in providing reliable, high-quality products to both corporate clients and general consumers all over the world, Mitsubishi Electric

Corporation is a recognized world leader in the manufacture, marketing and sales of electrical and electronic equipment used in information processing and communications, consumer electronics, industrial technology, energy, transportation and construction. No matter what you do, or where you live, work or play, chances are a Mitsubishi Electric product touches your life.

■ Mitsubishi Electric provides a wide variety of commercial and residential heating and air conditioning products. Thanks to Mitsubishi Electric's many exclusive technologies like **VCSi**, **VRF** and **H²i**, rest assured that all of our HVAC products are engineered to perform at the highest levels of efficiency and comfort. You'll find **City Multi** in high rise buildings and hotels, meeting demands from multiple occupants. And working behind the scenes 24/7 is **Mr. Slim P-Series**, maintaining constant and comfortable temperatures in retail stores, mechanical rooms or server rooms. With **Mr. Slim M-Series** you'll always feel welcome with the ultimate in home comfort. And **Zuba-Central** fits into your existing ductwork to provide a year-round whole-home comfort experience with outstanding energy savings. For more information on these products visit www.MitsubishiElectric.ca.

The Mitsubishi Electric Difference

■ Our commitment to innovation and technology is exceeded only by our commitment to service – we stand behind every product that bears the Mitsubishi name. And we demonstrate this by offering you our 2-year parts and 7-year compressor warranty that's among the best in the industry.

Through our competent distributor network, strong service support and unmatched parts availability, it is our assurance to you that you will enjoy the comfort and true quality that only Mitsubishi Electric can offer.



A Green Step in the Right Direction

■ Look at the commercial buildings around you and chances are that you'll find a Mitsubishi Electric HVAC system quietly and efficiently working behind the scenes. And because Mitsubishi Electric is always striving to make advancements in heating and air conditioning technologies, it's no surprise to find us at the forefront of geothermal applications like the one featured here.



Québec City

LEED-NC GOLD CERTIFICATION

This building uses up to 55% less energy than a building of similar size. That's enough to power 110 single-family homes each year.

This project, Place de L'Escarpement in Québec City, has the capacity of nearly 4 million Btu/h supplied by multiple City Multi WR2 systems which simultaneously heat and cool over 148,000 sq. ft. of floor space using geothermal energy. Place de L'Escarpement is one of the 10 most efficient of its class in Canada.

SYSTEM INSTALLED

Geothermal Units: City Multi WR2 systems x 37

Indoor Units: Ceiling-Concealed units x 269

Fresh Air Equipment: Lossnay/RenewAire HE2XINH x 7

Controller: Centralized controller G-50A x 7

E-mail Notification License x 7

BACnet Interface x 7

Simple Remote Controller x 269



Certificate Number 79222 Certificate Number 78649

Mitsubishi Electric Consumer Products has acquired ISO 9001 certification under Series 9000 of the International Standard Organization (ISO). The plant has also acquired environmental management system standard ISO 14001 certification.

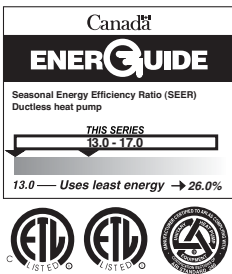

Mitsubishi Electric
Sales Canada Inc.

www.MitsubishiElectric.ca



Environmental Vision 2021

■ Environmental Vision 2021 stands at the core of Mitsubishi Electric's commitment to the environment, and outlines targets that we aspire toward and that we measure ourselves against. Our goal is to establish a framework for realizing a sustainable planet, and define long-term initiatives to prevent global warming and work toward the realization of a sustainable society. Utilizing our wide-ranging and sophisticated technologies as well as promoting assertive and persistent actions by our employees will help us arrive at that imperative result. The Vision sets 2021 as the target year, commemorating the 100th anniversary of Mitsubishi Electric's founding.

MITSUBISHI ELECTRIC
Changes for the Better